

BEAM MICROVAC MODEL 1501-L

VACUUM SAFETY SWITCH 6 OR 12 VOLT D.C.

- Total Weight 5-Ounces.
- Housing is Die Cast Aluminium.
- Furnished with Terminals and Electrical Harness Clamp, as Pictured.
- Enclosed Points: Positive Snap Action; No Arcing.
- Instant Closing of Precision Points at Starting Vacuum.
- Vacuum Connection is On Side Opposite Terminals for Accessibility to Wiring.

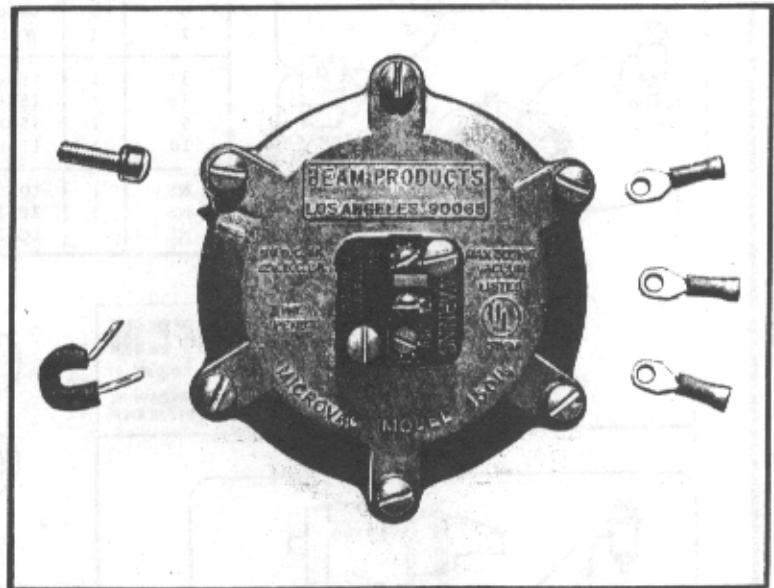

- Set to Close Between 2-Inches and 2½ Inches of Water, Vacuum.
- Large Diaphragm: Switch Stays Closed Whenever Engine is Running; Remains Closed Down to 1½ Inches Water Column.

SPECIFICATIONS

Working Pressure: Maximum 30-Inches Mercury, Vacuum

Electrical Rating: 6-Volt D.C. 4-Amperes
12-Volt D.C. 2-Amperes

Vacuum Connection: ½ Inch Female Pipe



Features a subminiature microswitch. A switch of this type is required on most fork lift installations as a safety measure to open the solenoid valve circuit and prevent fuel flow should the engine stop (even with ignition switch still on.) Switch will remain closed on small one or two-cylinder engines.

Microvac has an insulated terminal block with three screw type terminals, well marked so that one model can be used as either a two-wire or three-wire switch. The sturdy terminal block (1501-25) fits securely over the 3-spade terminals and can be installed on the earlier 1501-K3 switches in the field; order kit 1501-27.

Installation: Since the Microvac is generally used with Beam regulator models 120A, 100A, 60 or 50, the same vacuum line which operates the vacuum-lock in the regulator can also accommodate the switch. Use a street tee at the regulator and make a single vacuum connection.

Repairs: Two holes in the body are offset so that the diaphragm cannot be installed upside down. Note the small register line on each casting and the corresponding tip on the diaphragm. All three marks must line up when the switch is assembled.

Never short the Microvac terminals to ground. The Microvac is a precision unit and will not stand heavy surges of current which bypass the solenoid valve circuit.

Springs and switches are matched; keep them together. To insure the vacuum spring being inserted on the correct side of the diaphragm, casting is marked in the spring depression area. Be sure that the microswitch is installed with red operator button in the center so that it will properly contact the rivet in the diaphragm.

See Form F-145 for use with 450B Regulator

MICROVAC MODEL 1501-L VACUUM SAFETY SWITCH

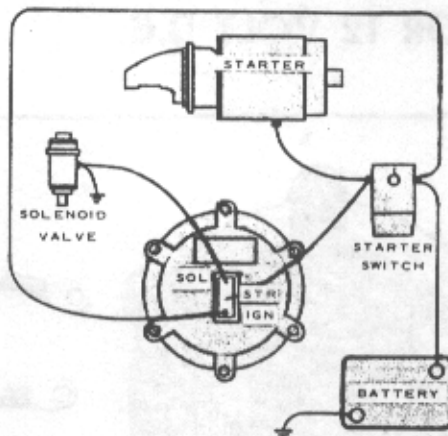

MAGNETO IGNITION

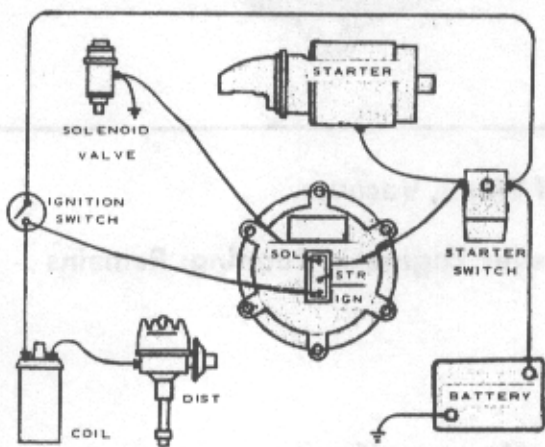

BATTERY IGNITION

ELECTRICAL CONNECTIONS

1. Install Microvac at any convenient source of manifold vacuum, away from the heat of the exhaust system.
2. Use 16-gauge primary automotive wire. Insulated terminals are provided. To avoid mistakes, connect one circuit at a time as follows:
3. Connect "SOL" (Solenoid) terminal of Microvac to electric solenoid valve or Filterlock.
4. Connect "IGN" (Ignition) terminal of Microvac to coil side terminal of ignition switch. If there is no bypass resistor in the ignition circuit, this wire may be connected to the battery terminal of the ignition coil.

For use as a **2-wire** switch, simply do not connect the center terminal; use the two outside terminals only. Proceed to step 6.

For use as a **3-wire** switch, proceed with steps 5 and 6.

Ref. No.	No. Req.	Part Number	Description of Part	1501-26 Kit---switch replacement	1501-27 Kit---adapter		
1	6	103208-FS	Screw---	machine w/lockwasher			
2	1	1501-6	Diaphragm---	Microvac			
3	1	1501-24	Shim---	microswitch	1	1	
4	1	1501-25	Adapter---	terminal	1	1	
5	2	063207-B	Screw---	machine 6-32 x 7/16"	2	2	
6	3	044003-RB	Screw---	machine 4-40 x 3/16"	3	3	
7	3	W04-T	Washer---	external star #4	3	3	
8A	1	1501-28A	Microswitch---	(includes spring 1501-5)			1
8B	1	1501-5	Spring---	matched to microswitch			1
9	1	1501-23	Cover---	front			
10	1	1501-21	Cover---	back			
NS	1	103210-FS	Screw---	machine	1	1	
NS	3	2E-101	Terminal---	solderless	3	3	
NS	1	1C-210	Clamp---	neoprene	1	1	

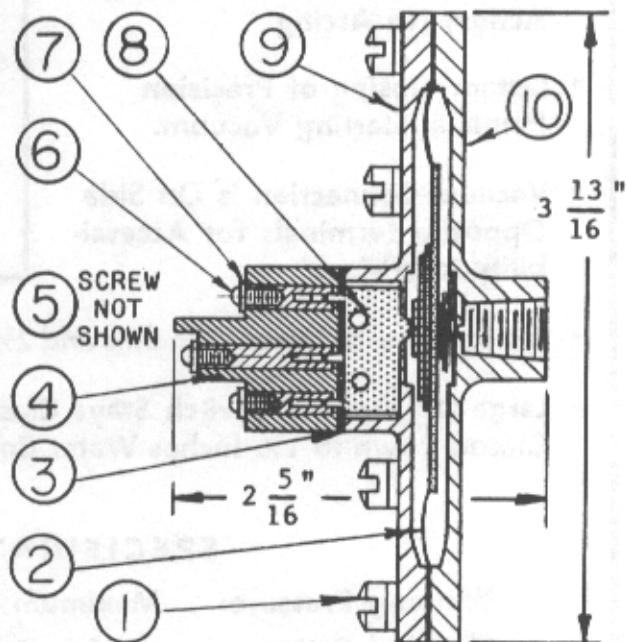

5. Connect center "STR" (Starter) terminal of Microvac to terminal on starter switch which goes to starter. Engaging starter will complete circuit to solenoid valve only while the starter is energized.
6. Secure all the electrical wires to the Microvac. After installation, remove one screw at the most convenient location, replace it with the longer screw and clamp provided. Run all wires through the clamp and tighten. This will avoid vibration at the terminals and extend their life.

STARTING THE ENGINE

2-wire Installation: Start engine on a closed throttle or use a pumping action to allow the throttle to close momentarily to build up manifold vacuum to close the normally open circuit ("IGN" to "SOL"). Solenoid valve will remain open as long as manifold vacuum is present.

3-wire Installation: Normally, the engine will start at any throttle position. The normally closed circuit (step 5, "STR" to "SOL") will automatically open to avoid current feedback after the engine starts.